

## Important information

### Caution

This product must be installed in accordance with the applicable installation code by a person familiar with the construction and operation of the product and the hazards involved. We recommend you use a licenced electrician.

This product is designed to be wall mounted and is suitable for use outdoors in wet locations. Follow detailed instructions for wet location installation. To reduce the risk of fire, electrical shock, or injury to persons, turn off power before installation or maintenance. Do not use luminaire with a damaged lens, body or cable.

### Installation

This product is designed to fit in to a standard junction box (J-Box) having minimum inside dimensions of 47mm(1.84")W x 73mm(2.89")H x 61mm(2.4")D.

For mortar or poured concrete installation, use appropriate water proof junction box suitable for that application. J-Box is not provided.

### For indoor installation – Vertical application

Fig. 1

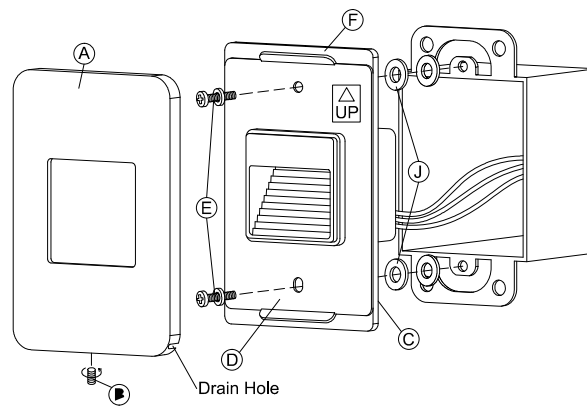
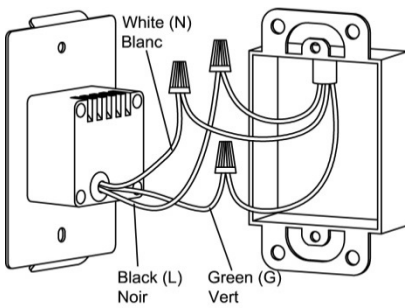

Wet Location Installation

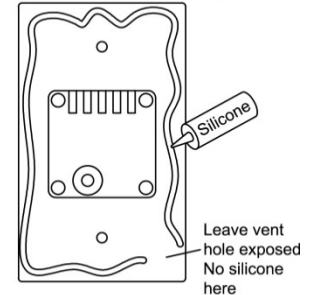

- 1) Single gang J-Box should be mounted 1.6mm(1/16") behind wall surface.
- 2) Separate faceplate (A) from main body by loosening set screw (B) with allen key provided.
- 3) Fixture is now ready to be installed in vertical orientation.
- 4) For indoor application rubber gasket (C) is not required and can be discarded. Use one or two washers (J) to compensate for unused gasket.
- 5) Make electrical connection as per instructions. (Fig. 1) Connect black fixture wire to black wire from J-Box, white wire to white neutral wire from J-Box, and green fixture wire to (ground) green wire or bare copper wire from J-Box. Use proper size wire nuts (marrets) – not supplied. Make sure connections are completely covered. Gently place all wiring back into J-Box.  
\*Multiple fixtures can be wired together in parallel.
- 6) You are now ready to attach back plate (D) to J-Box. Use two mounting screws (E) provided, to secure back plate (D) to J-Box. Tighten securely.
- 7) Faceplate (A) can now be installed. Hook top of faceplate onto tab (F). Push bottom of faceplate towards the wall until flush. Tighten set screw (B).

### For indoor installation – Horizontal application

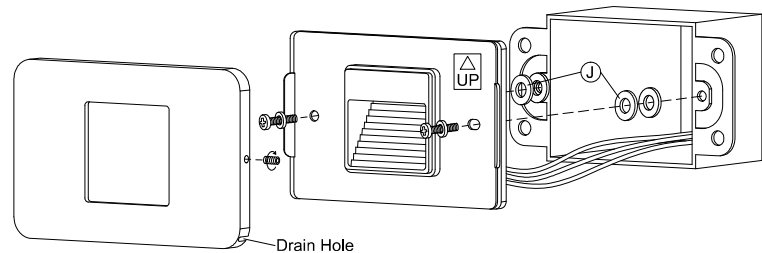
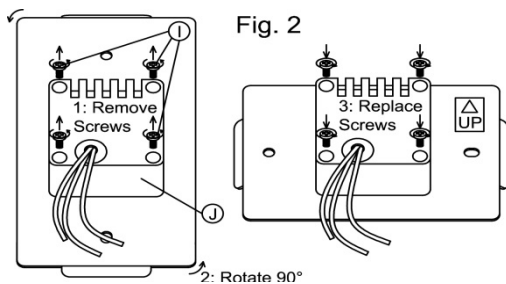

- 1) Fixture always shipped ready for vertical orientation. To change orientation follow instructions in Fig. 2
  - Open four screws (I)
  - Rotate light engine (J) quarter turn.
  - Tighten four screws (I)
  - Use same instructions for vertical installation.

## Waterproof installation

For outdoor installations please incorporate the following procedures:

- 1) The standard metal J-Box can be used for outdoors installations. However if box is to be seated in mortar or poured concrete, use waterproof box with waterproof connectors.
- 2) Use rubber gasket for outdoor installation.
- 3) We recommend that installer run a bead of clear, outdoor rated silicone between gasket and wall surface. This will prevent seepage of water into fixture. Be careful not to plug drain hole.

## Dimming

This product can be dimmed if required. The only dimmer approved for this function is Lutron-MAELV. Use of any other dimmer will void warranty.

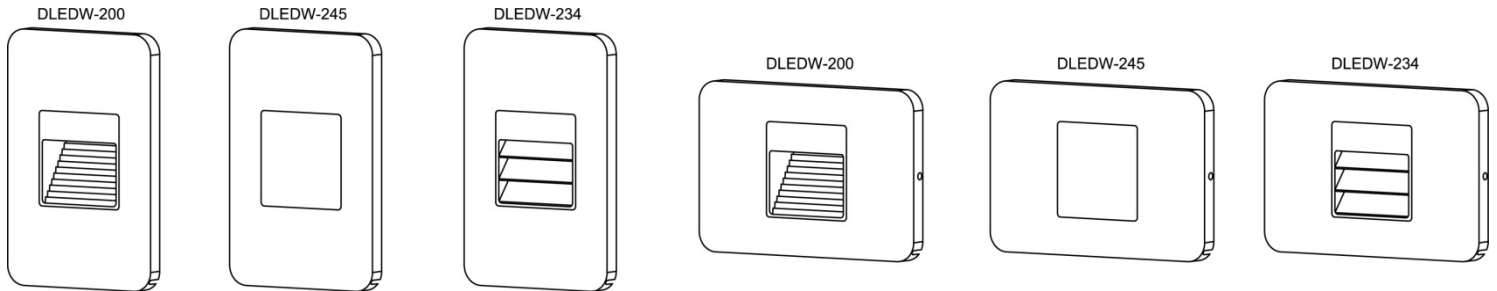

## WARRANTY

Dainolite Ltd. offers a **5 year** factory warranty from date of purchase on all LED wall light products. This warranty is expressly limited to repair or replacement of defective product only. Any consequential damages or labor costs arising from a defect are excluded.

Not all dimmer switches are compatible to be used with Dainolite Ltd. LED products. Consult product instruction sheet for list of approved dimmers. Use of unapproved dimmer will nullify your warranty.

Dainolite's obligation under this warranty shall not extend beyond the distributor's initial purchase price of the product. This warranty does not apply to products that have been altered, improperly installed, mishandled or misused.

**DO NOT RETURN PRODUCT TO THE RETAILER.**

### For warranty:

Contact the factory directly in writing: Email [dainolite@dainolite.ca](mailto:dainolite@dainolite.ca). Include copy of purchase invoice and describe defect. A factory person will contact you directly to advise what further action will be taken.

### For missing hardware or broken glass:

Contact the factory directly in writing: Email [dainolite@dainolite.ca](mailto:dainolite@dainolite.ca). The missing or broken parts will be shipped to you directly the same day after receipt of your email (weekend excluded).